

(No Model.)

W. A. JOHNSTON.  
Treadle Mechanism for Dental Engine.

No. 229,614.

Patented July 6, 1880.

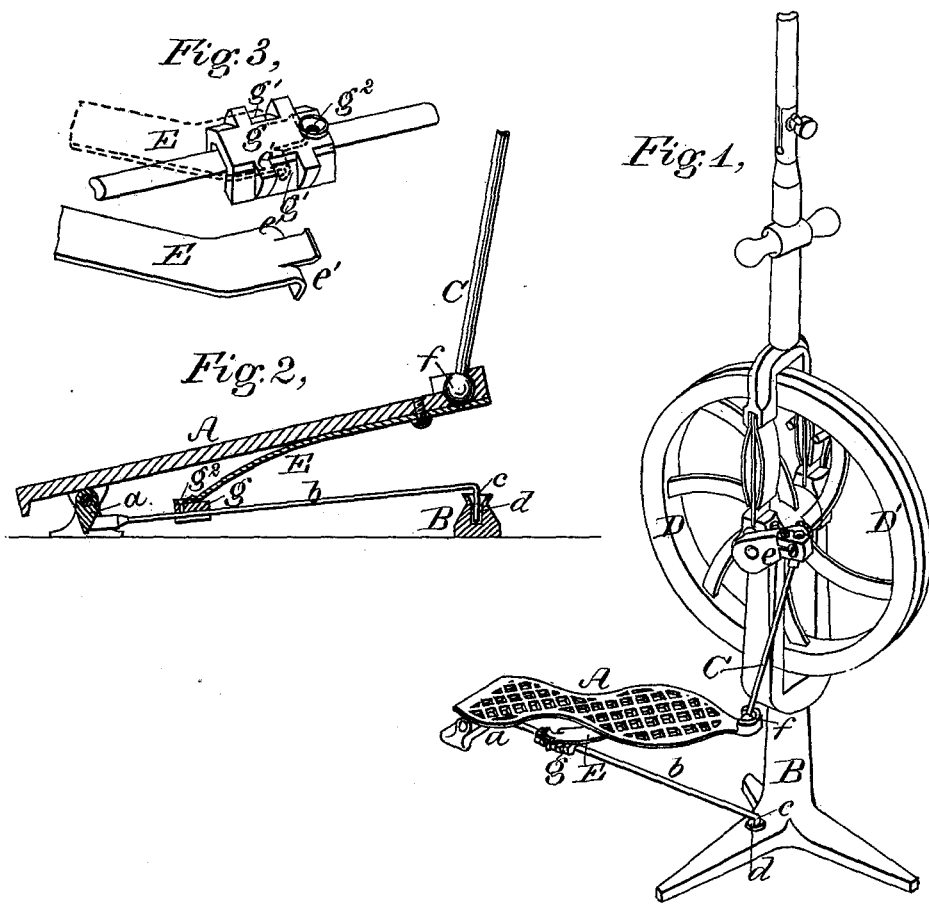

WITNESSES

*George*  
*Clarke*

INVENTOR

*Wm. A. Johnston,*  
*by H. Saily*  
his ATTORNEY.

# UNITED STATES PATENT OFFICE.

WILLIAM A. JOHNSTON, OF EDGEWATER, NEW YORK.

## TREADLE MECHANISM FOR DENTAL ENGINES.

SPECIFICATION forming part of Letters Patent No. 229,614, dated July 6, 1880.

Application filed March 30, 1880. (No model.)

*To all whom it may concern:*

Be it known that I, WILLIAM A. JOHNSTON, of the village of Edgewater, county of Richmond, and State of New York, have invented certain new and useful Improvements in Treadle Mechanism for Dental Engines and other purposes, of which the following is a specification.

My invention relates to a treadle mechanism which I have designed with special reference to the requirements of a dental engine or lathe, but which is applicable also to other machines designed to be operated by foot-power.

It consists in providing the treadle with an elevating-spring, which partly raises the treadle and tends to keep the crank off the center, and in combining therewith a fly or driving wheel slightly out of balance, so that the wheel will tend to come to rest at a point where the treadle will be partly raised, and the crank will be to that side of the center where it should be, in order to insure that the wheel shall start in the proper direction.

It also consists in the means hereinafter described for mounting the free end of the spring upon the guide on or over which that end moves when the treadle oscillates.

In the drawings accompanying this specification, Figure 1 is an isometrical perspective view of so much of a dental lathe or engine as required to illustrate my improvements. Fig. 2 is a longitudinal vertical central section of the treadle on an enlarged scale. Fig. 3 is a perspective view of a portion of the guide rod or bar and spring, and of the box which is interposed between said rod and the lower or free end of said spring.

The treadle mechanism consists of a treadle, A, jointed to a base-plate, a, attached to or forming part of a bar, b, which at its forward end is provided with a vertical pivot-pin, c, entering a socket, d, in the pedestal B of the engine.

The pitman-rod C is jointed at one end to the crank e of the fly-wheel D, and at its other end is connected, by a universal or ball-and-socket joint, f, with the treadle. The center of motion of the crank and the joints d and f are in line, so that the treadle may be swung

around in any direction on its pivot c, and still maintain its proper position with respect to the pitman and crank.

The treadle mechanism thus far is substantially the same as that of the well-known Morrison dental engine. With the treadle in the present instance, however, is combined an elevating-spring, whose preferred form and arrangement are shown in the drawings. It consists of a flat plate-spring, E, fast at its upper end to the treadle, and bearing at its lower end down against the horizontal bar b. The spring is so adjusted as to partly raise the treadle, and thus to hold the crank off the center. In order that its lower end may reciprocate easily during the rise and fall of the treadle, I interpose between the spring and the bar a half-round box or bearing, g, provided with side pockets, g', which are engaged by ears e' on the lower end of the spring, and also with a lubricating-passage, g<sup>2</sup>, through which oil may be dropped to lubricate that part of the bar traversed by the box during the movement of the treadle.

In order that the fly-wheel shall stop in the correct position to insure its revolution in the proper direction when the engine is again started, I make it slightly out of balance, the preponderance being on the side marked D'.

If the fly-wheel in stopping has sufficient momentum to pass the lower center of the crank, the recoil of the depressed treadle will throw it over around the upper center, and it will then vibrate on the side D' within the limits of the half-circle on that side of the upper and lower centers until it comes to rest in the position shown in Fig. 1, which is the position of equilibrium between the overbalanced wheel above and the elevating-spring below. The parts, if left to themselves, will always come to rest in this position, and when so placed the wheel, when the engine starts again, will revolve in the proper direction.

The fly-wheel has its bearings in a yoke formed in the pedestal, as shown, and is straddled by the forked lower part of the standard which carries the operating parts of the engine. A band or belt extending from the fly-wheel to a suitable pulley at the upper end of

the standard serves to communicate movement from one to the other. It is not necessary, however, for the purpose of explaining my invention to further refer to these parts.

5 What I here claim, and desire to secure by Letters Patent, is—

1. The combination, with the treadle mechanism, of a spring for raising the treadle and a fly or driving wheel slightly out of balance, substantially as and for the purposes herein-  
10 before set forth.

2. The combination, substantially as hereinbefore set forth, in treadle mechanism, of a jointed treadle, an elevating-spring, a box or

bearing engaging the lower part of the spring, 15 and a guide upon which said box can move.

3. The combination of the fly-wheel slightly out of balance, the jointed treadle, the rod and crank connecting the same with the fly-wheel, and the elevating-spring, the combination be- 20 ing and acting substantially as hereinbefore set forth.

In testimony whereof I have hereunto set my hand this 29th day of March, 1880.

WILLIAM A. JOHNSTON.

Witnesses:

JOHN J. CHAPIN,  
CHARLES J. SOLYAM.